



Grid ACADEMY

© America Revealed

Distribution Impacts

Joseph G Waligorski

Technical Advisor • FirstEnergy

Nov. 18, 2014



NATIONAL ACADEMY
OF SCIENCES
Science & Engineering Ambassadors



NATIONAL ACADEMY
OF ENGINEERING



The modern system will have changes in all of these elements, some more than others

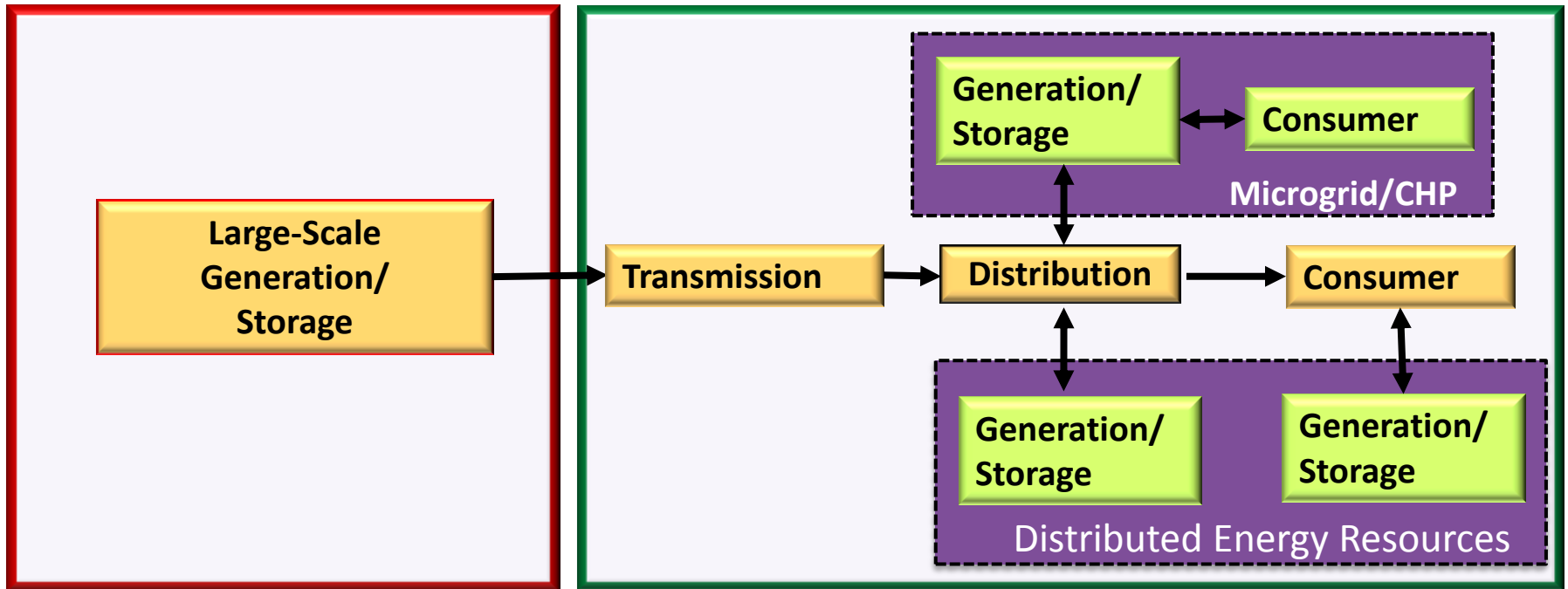

Smart Distribution Systems: Automation

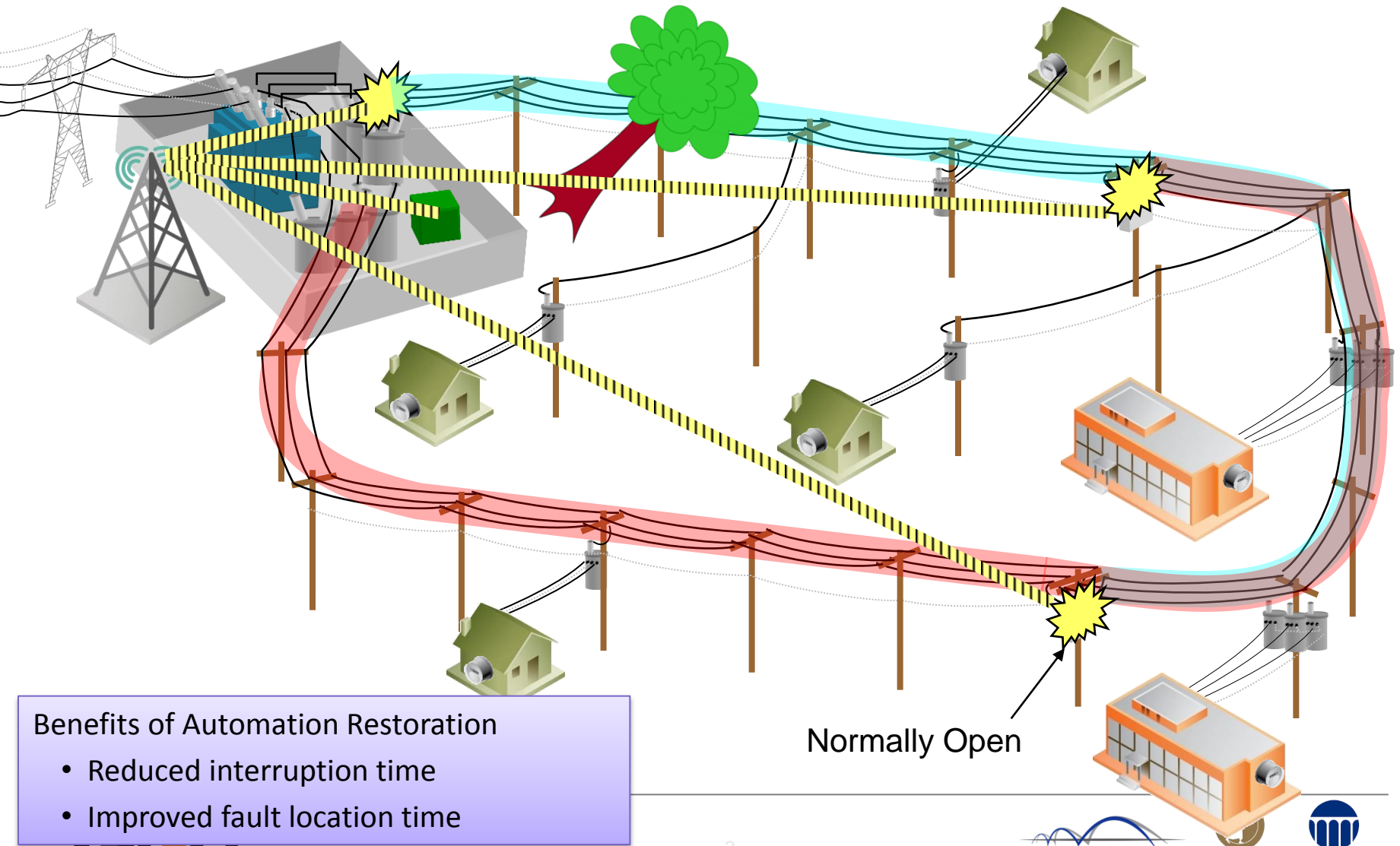

Benefits of Automation Restoration

- Reduced interruption time
- Improved fault location time

DER Technologies



Gas Turbines



Reciprocating Engines



Fuel Cells



Photovoltaics



Wind



Energy Storage



Microturbines

Utility scale/ **large commercial** larger than 1 MW
Medium scale/ **small commercial** 10 kW - 1 MW
Small scale/ **small residential** less than 10 kW

Voltage rise due to large DG

- Steady state voltage regulation issue due to reverse power flow

Voltage variations due to variations in solar output

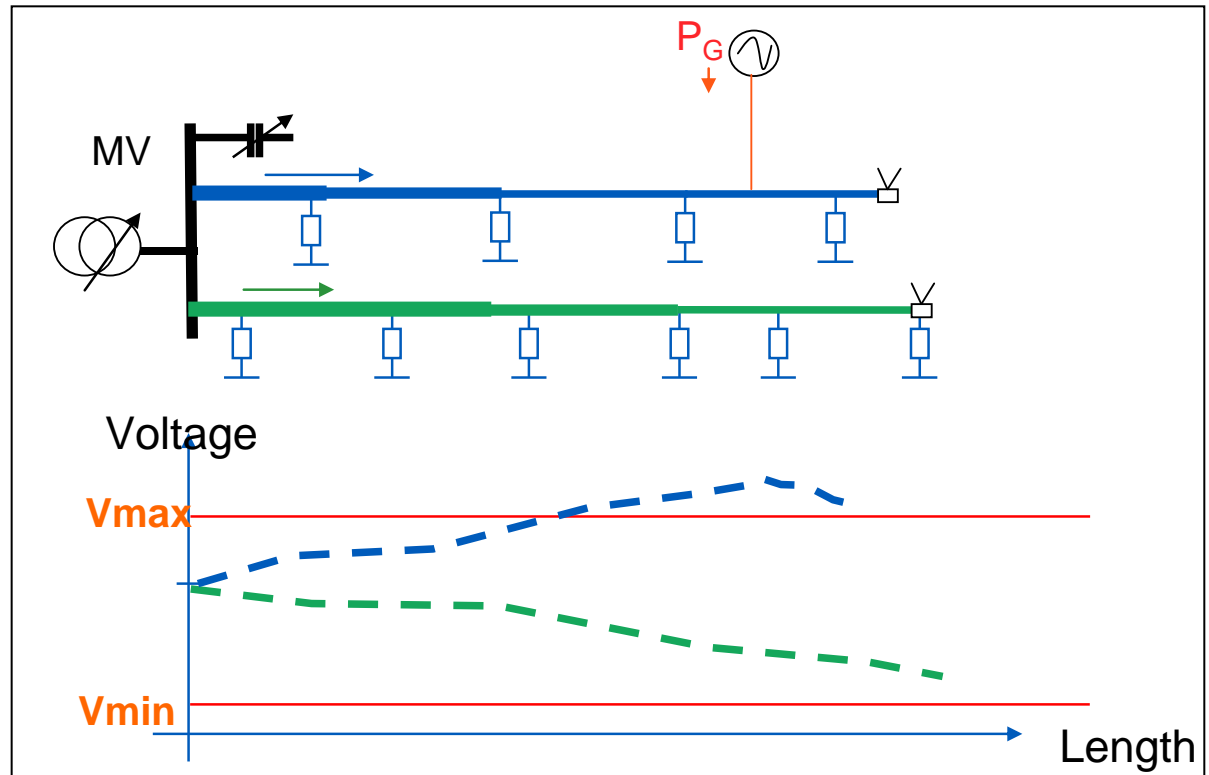
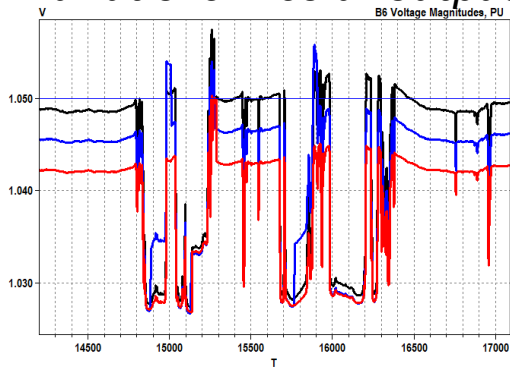

Source: Sébastien GRENARD; EDF R&D; France

Protection Issues

Possible Impact on relay coordination

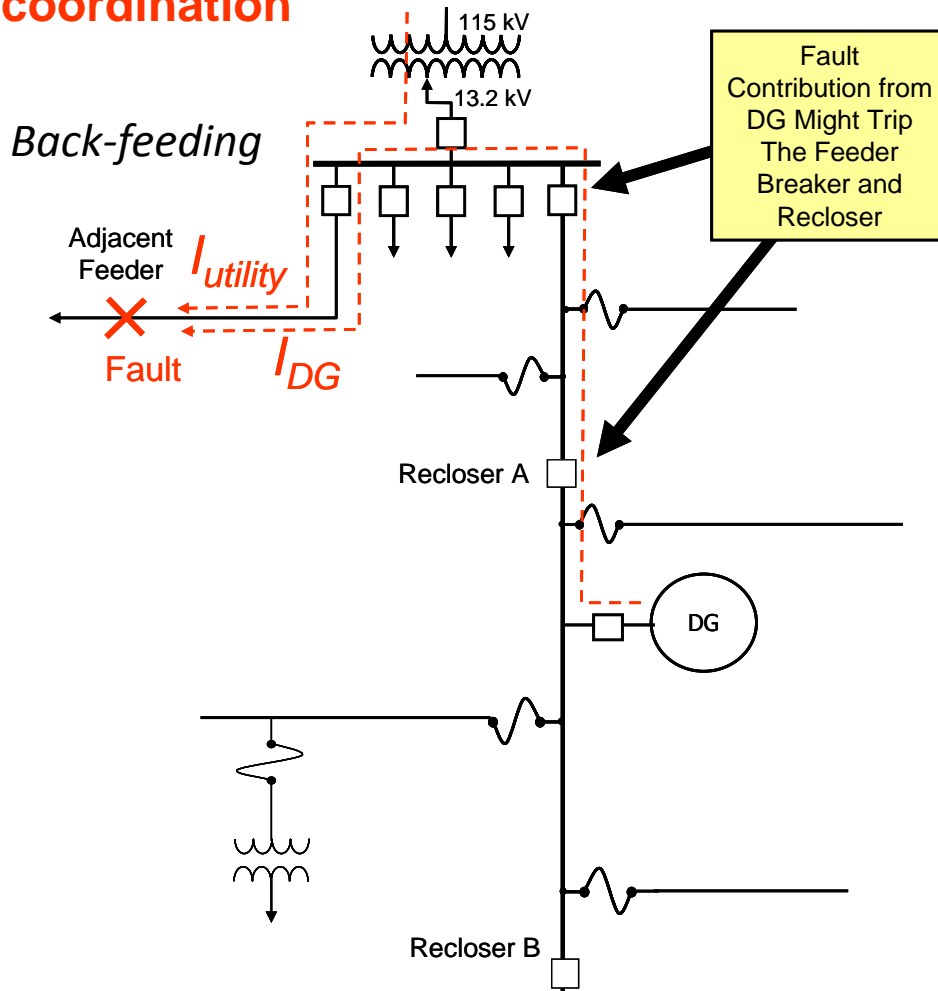

Possible Impact on Fuse Saving Schemes

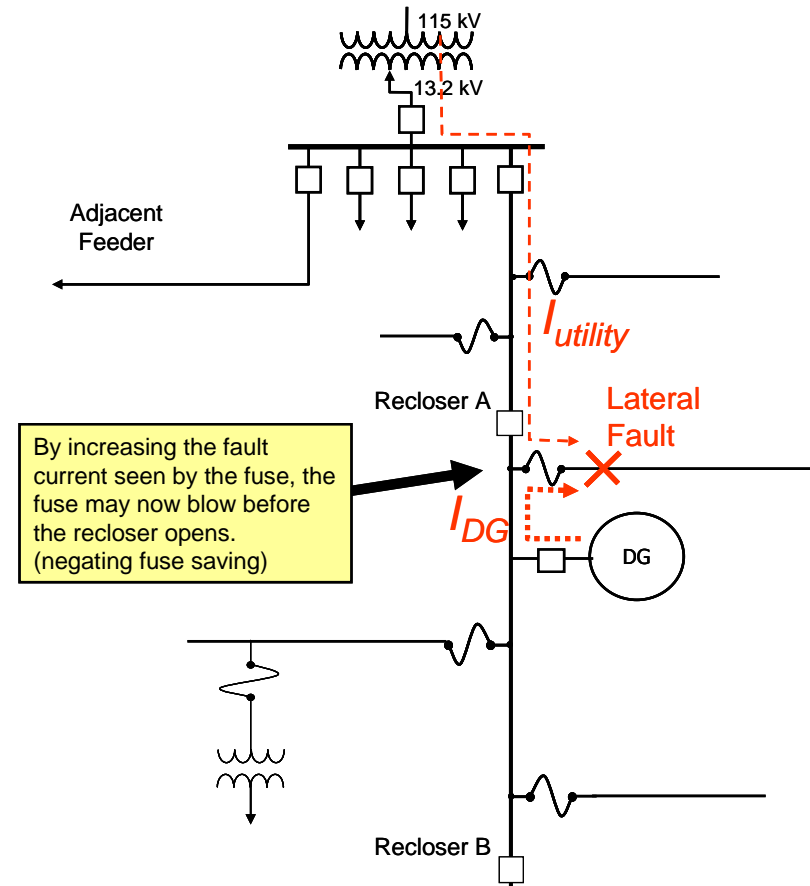

To the Future

We're not there yet -

What we need ;

- Advanced modeling software – for dynamic distribution system
- Communications – Reliable, Secure
 - Reliable in disturbances/ failsafe design
 - Secure for data and control
- Protection advancements - accommodate integration of DER rather than retrofit of existing infrastructure.

Questions?